

Injection mortar FIS V Plus

The powerful universal mortar for concrete and masonry

3



Steel constructions



Rescue ladders

Applications

Injection mortar for use with:

- Threaded rods FIS A, see page PL
- Internal threaded anchor RG MI, see page PL
- Rebar anchor FRA, see page PL
- Concrete steel bars, see page PL
- Injection anchor sleeves FIS H, see page PL
- Aerated concrete centring sleeve PBZ, see page PL
- Remedial wall tie VBS 8, see page PL
- Weather facing reconstruction system FWS II, see page PL

Advantages

- The FIS V Plus injection mortar has numerous system approvals, such as in cracked and non-cracked concrete, masonry and for special applications.
- The ETA assessment for a service life of 100 years offers permanent safety for all applications.
- The approved use in water-filled drill holes enables a wide range of applications, even under harsh environmental conditions.
- FIS VW Plus High Speed has a significantly shorter curing time than FIS V Plus, thus also ensuring swift work progress even at low temperatures.
- Due to the possible installation temperature of -10° to 40°C the universal mortar can be applied all year long.
- FIS VS Plus Low Speed with extended gelling time prevents premature curing of the mortar at higher temperatures and is ideally suited to large drill hole depths.
- The extensive range of accessories is ideally suited to the FIS V Plus injection mortar family, increases the great flexibility of the system and thus allows for a broad range of applications.

Certificates



ETA-20/0603, for concrete

ETA-20/0728, for post-installed rebar connections

ETA-20/0729, for masonry



Fire resistance classification R120



Building materials

Approved for anchorings in:

- Concrete C20/25 to C50/60, cracked and non-cracked
- Hollow blocks made from lightweight concrete
- Hollow blocks made from concrete
- Vertically perforated brick
- Perforated sand-lime brick
- Solid sand-lime brick
- Aerated concrete
- Solid brick

Approved for:

- Rebar connections
- Remedial wall tie VBS 8
- Weather facing reconstruction system FWS II
- Stand-off installation TherMax

Functioning

- The FIS V Plus is a 2-component injection mortar based on vinyl ester hybrid.
- Resin and hardener are stored in two separate chambers and are not mixed and activated until extrusion through the static mixer.
- The injection cartridges are quick and easy to use with the fischer dispensers.
- Partially used cartridges can be reused, simply by changing the static mixer.

Installation in concrete with FIS V Plus and FIS A / RG M

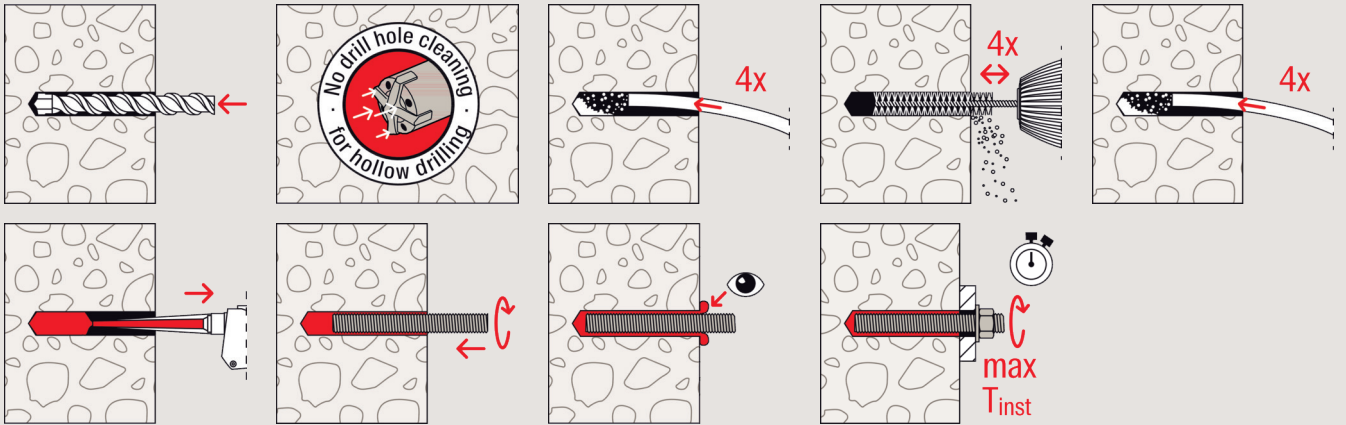

3

Installation in concrete with FIS V Plus and RG M I

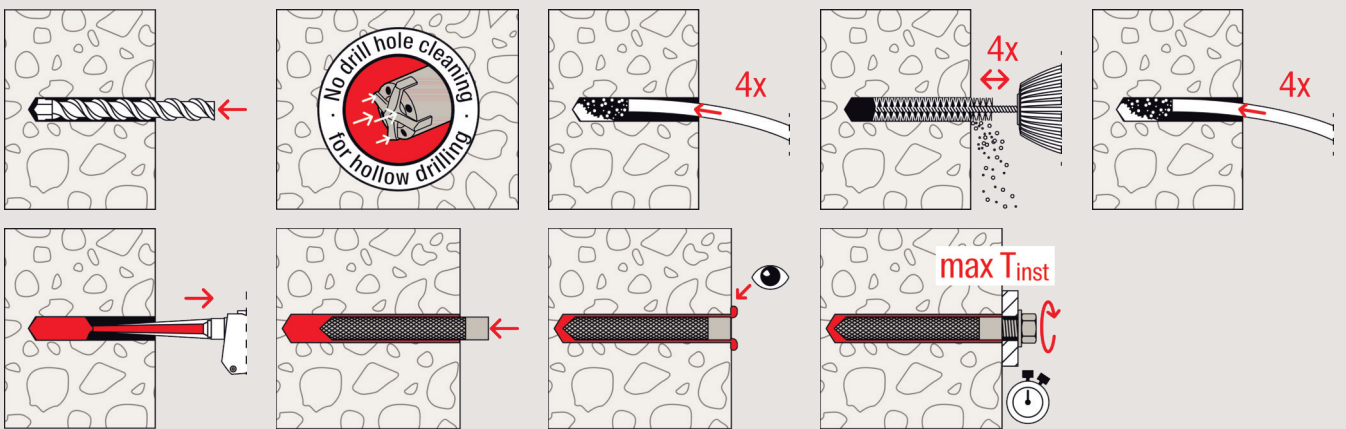

Installation in solid brick with FIS V Plus and FIS A

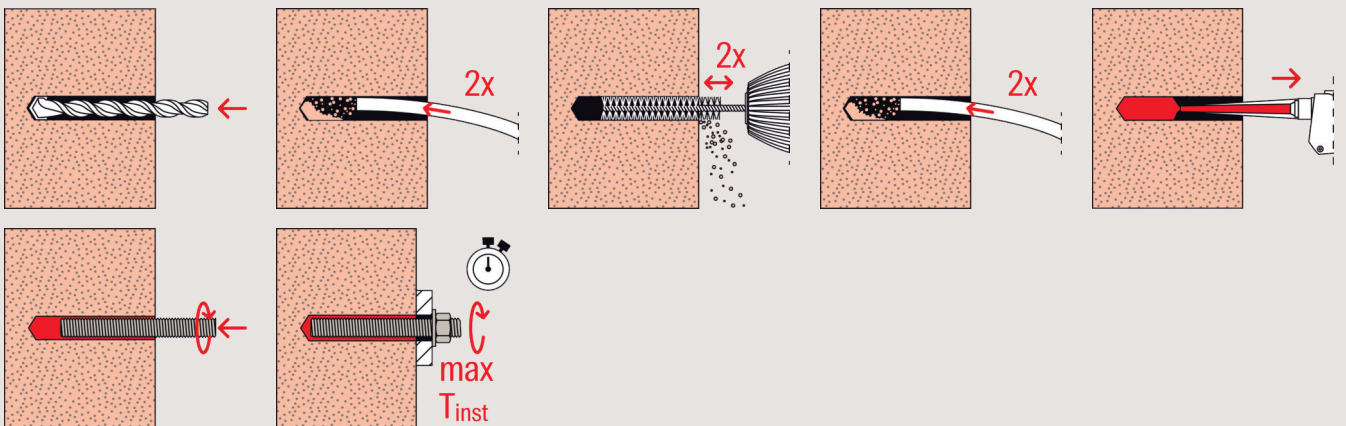

Installation in hollow blocks with FIS V Plus and FIS HK + FIS A

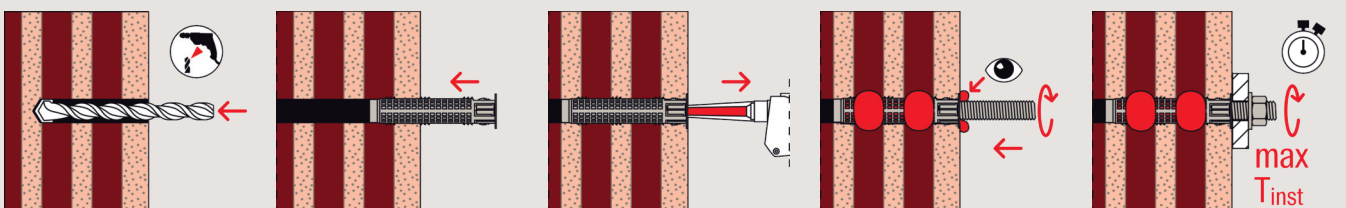

Installation in aerated concrete with FIS V Plus and FIS A / RG M

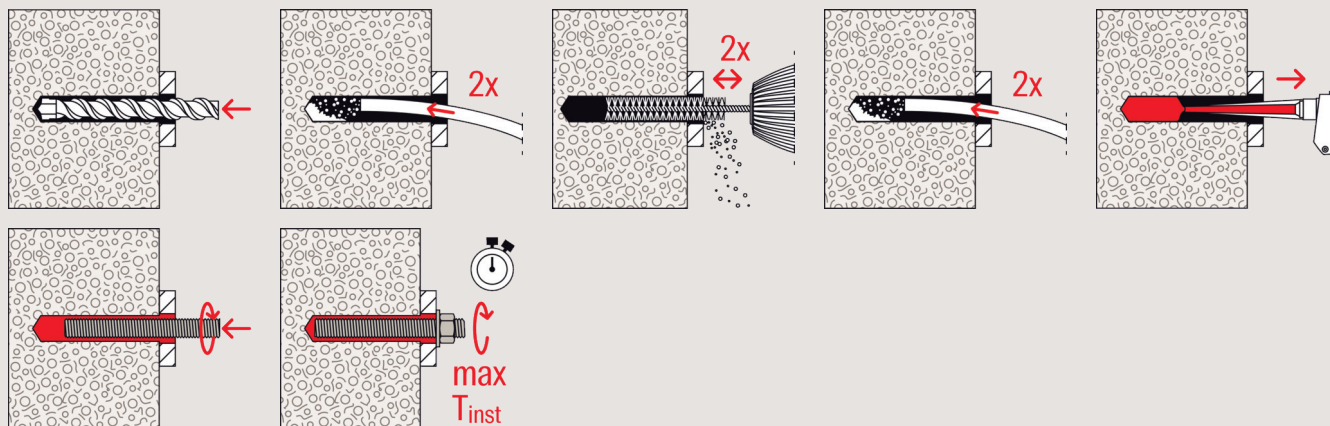

Installation in undercut drill hole in aerated concrete with FIS V Plus and FIS A / RG M

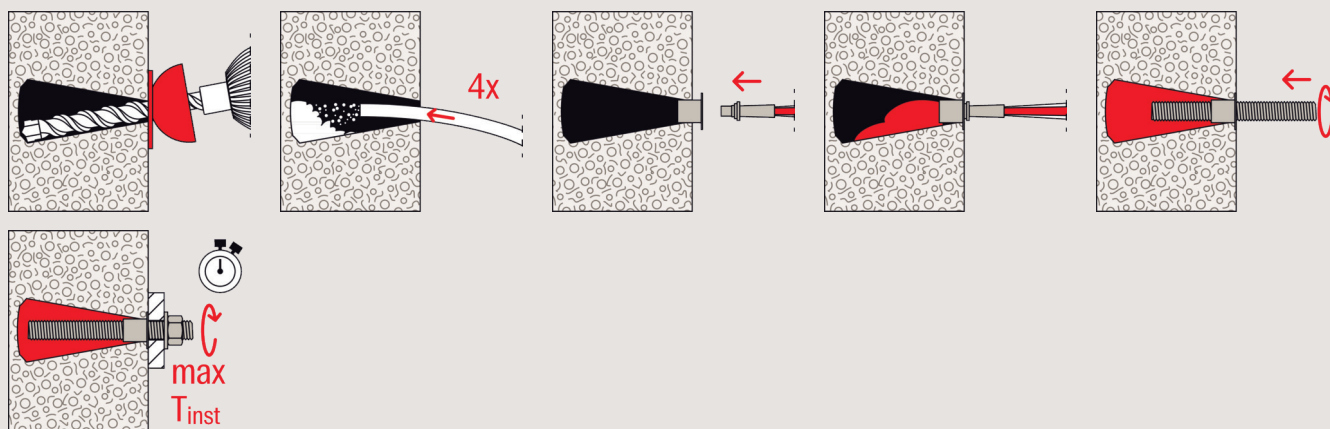

Technical data



FIS V Plus 360 S

Item	Item No.	Approval			Languages on the cartridge	Contents	Sales unit [pcs]
		DIBt	ETA	ICC			
FIS V Plus 360 S (IN)	558744	●	●	●	EN	1 cartridge 360 ml, 2 x FIS MR Plus	6
FIS V Plus 360 S (DE)	558745	●	●	●	DE	1 cartridge 360 ml, 2 x FIS MR Plus	6
FIS V Plus 360 S (EN,ES,PT)	558746	●	●	●	EN, ES, PT	1 cartridge 360 ml, 2 x FIS MR Plus	6
FIS V Plus 360 S (AR,ZH,EN)	558747	●	●	●	AR, ZH, EN	1 cartridge 360 ml, 2 x FIS MR Plus	6
FIS V Plus 360 S (DE,FR,NL)	558752	●	●	●	DE, FR, NL	1 cartridge 360 ml, 2 x FIS MR Plus	6
FIS V Plus 360 S (IT,PL,RO)	558753	●	●	●	IT, PL, RO	1 cartridge 360 ml, 2 x FIS MR Plus	6
FIS V Plus 360 S (TR,EL,AR)	558754	●	●	●	TR, EL, AR	1 cartridge 360 ml, 2 x FIS MR Plus	6
FIS V Plus 360 S (DK,NO,SE,FI)	558755	●	●	●	DK, NO, SE, FI	1 cartridge 360 ml, 2 x FIS MR Plus	6
FIS V Plus 360 S (EN,ES,PT)	558758	●	●	●	EN, ES, PT	1 cartridge 360 ml, 2 x FIS MR Plus	6
FIS V Plus 360 S (RU,UK,KK)	558760	●	●	●	RU, UK, KK	1 cartridge 360 ml, 2 x FIS MR Plus	6
FIS V Plus 360 S (CS,SK,HU)	558762	●	●	●	CS, SK, HU	1 cartridge 360 ml, 2 x FIS MR Plus	6

Technical data



FIS VS Plus 360 S

Item	Item No.	Approval			Languages on the cartridge	Contents	Sales unit [pcs]
		DIBt	ETA	ICC			
FIS VS Plus 360 S (ZH,JA,KO)	558749	●	●	●	ZH, JA, KO	1 cartridge 360 ml, 2 x FIS MR Plus	6
FIS VS Plus 360 S (EN,ES,PT)	558750	●	●	●	EN, ES, PT	1 cartridge 360 ml, 2 x FIS MR Plus	6

3

Technical data



FIS VW Plus 360 S

Item	Item No.	Approval			Languages on the cartridge	Contents	Sales unit [pcs]
		DIBt	ETA	ICC			
FIS VW Plus 360 S (DE)	558759	●	●	●	DE	1 cartridge 360 ml, 2 x FIS MR Plus	6
FIS VW Plus 360 S (EN,HU)	558764	●	●	●	EN, HU	1 cartridge 360 ml, 2 x FIS MR Plus	6
FIS VW Plus 360 S (DE,FR,NL)	558765	●	●	●	DE, FR, NL	1 cartridge 360 ml, 2 x FIS MR Plus	6
FIS VW Plus 360 S (RU,UK,KK)	558767	●	●	●	RU, UK, KK	1 cartridge 360 ml, 2 x FIS MR Plus	6
FIS VW Plus 360 S (PL,CS,RO)	558768	●	●	●	PL, CS, RO	1 cartridge 360 ml, 2 x FIS MR Plus	6

Technical data



FIS V Plus 360 S HWK K

Item	Item No.	Approval			Languages on the cartridge	Contents	Sales unit [pcs]
		DIBt	ETA	ICC			
FIS V Plus 360 S (DE) HWK K	558770	●	●	●	DE	10 cartridges 360 ml, 20 static mixer FIS MR Plus	1
FIS V Plus 360 S (CS,SK,HU) HWK K	558771	●	●	●	CS, SK, HU	10 cartridges 360 ml, 20 static mixer FIS MR Plus	1
FIS V Plus 360 S (DE,FR,NL) HWK K	558769	●	●	●	DE, FR, NL	10 cartridges 360 ml, 20 static mixer FIS MR Plus	1

Technical data



FIS V Plus 360 S HWK G

3

Item	Item No.	Approval			Languages on the cartridge	Contents	Sales unit [pcs]
		DIBt	ETA	ICC			
FIS V Plus 360 S (DE) HWK G	558756	●	●	●	DE	20 cartridges 360 ml, 40 static mixer FIS MR Plus	1
FIS V Plus 360 S (AR,ZH,EN) HWK G	558748	●	●	●	AR, ZH, EN	20 cartridges 360 ml, 40 static mixer FIS MR Plus	1
FIS V Plus 360 S (DE,FR,NL) HWK G	558757	●	●	●	DE, FR, NL	20 cartridges 360 ml, 40 static mixer FIS MR Plus	1

Technical data



FIS VW Plus 360 S HWK G

Item	Item No.	Approval			Languages on the cartridge	Contents	Sales unit [pcs]
		DIBt	ETA	ICC			
FIS VW Plus 360 S (DE) HWK G	558766	●	●	●	DE	20 cartridges 360 ml, 40 static mixer FIS MR Plus	1

Technical data



FIS V Plus 360 S BT

Item	Item No.	Approval			Languages on the cartridge	Contents	Sales unit [pcs]
		DIBt	ETA	ICC			
FIS V Plus 360 S (DE,FR,NL) BT	558763	●	●	●	DE, FR, NL	20 cartridges 360 ml, 20 static mixer FIS MR Plus	1
FIS V Plus 360 S (IN) BT	558743	●	●	●	EN	20 cartridges 360 ml, 40 static mixer FIS MR Plus	1
FIS V Plus 360 S (AR,ZH,EN) BT	558751	●	●	●	AR, ZH, EN	20 cartridges 360 ml, 20 static mixer FIS MR Plus	1
FIS V Plus 360 S (RU,UK,KK) BT	558772	●	●	●	RU, UK, KK	20 cartridges 360 ml, 40 static mixer FIS MR Plus	1

Technical data



FIS V Plus 360 S HWK G +
FIS DM S

Item	Item No.	Approval			Languages on the cartridge	Contents	Sales unit [pcs]
		DIBt	ETA	ICC			
FIS V Plus 360 S (DK,NO,SE,FI) HWK G + FIS DM S	558775	●	●	●	DK, NO, SE, FI	12 cartridges 360 ml, 24 x FIS MR Plus, 1 x dispenser FIS DM S	1
FIS V Plus 360 S (DE,FR,NL) HWK G + FIS DM S	560032	●	●	●	DE, FR, NL	12 cartridges 360 ml, 24 x FIS MR Plus, 1 x dispenser FIS DM S	1
FIS V Plus 360 S (IT,PL,RO) HWK G + FIS DM S	558773	●	●	●	IT, PL, RO	12 cartridges 360 ml, 24 x FIS MR Plus, 1 x dispenser FIS DM S	1
FIS V Plus 360 S (CS,SK,HU) HWK G + FIS DM S	560033	●	●	●	CS, SK, HU	12 cartridges 360 ml, 24 x FIS MR Plus, 1 x dispenser FIS DM S	1

Technical data



FIS V Plus 410 C (IT,DE,EN)

Item	Item No.	Approval			Languages on the cartridge	Contents	Sales unit [pcs]
		DIBt	ETA	ICC			
FIS V Plus 410 C (EN,ES,PT)	558784	●	●	●	EN, ES, PT	1 cartridge 410 ml, 2 x FIS MR Plus	12
FIS V Plus 410 C (IT,DE,EN)	558780	●	●	●	IT, DE, EN	1 cartridge 410 ml, 2 x FIS MR Plus	12
FIS VW Plus 380 C (PL,CS,SK)	558785	●	●	●	PL, CS, SK	1 cartridge 380 ml, 2 x FIS MR Plus	12
FIS V Plus 410 C (IT,DE,EN) HWK G	558781	●	●	●	IT, DE, EN	16 cartridges 410 ml, 32 x FIS MR Plus	1
FIS V Plus 410 C (RU,EN,TR) BT	558783	●	●	●	RU, EN, TR	16 cartridges 410 ml, 32 x FIS MR Plus	1
FIS V Plus 410 C (IT,DE,EN) BT	558782	●	●	●	IT, DE, EN	16 cartridges 410 ml, 32 x FIS MR Plus	1

Technical data



Thermosafe case FIS V Plus

Item	Item No.	Approval			Contents	Sales unit [pcs]
		DIBt	ETA	ICC		
Thermosafe case FIS V Plus	558950	●	●	●	6 x cartridges 360 ml, 12 x static mixer FIS MR Plus, 1 x brush set, 1 x blow-out pump, 1 x dispenser FIS DM S	1

Curing times

FIS V Plus Cartridge temperature (mortar) [°C]	Maximum gelling time t_{work} [min.]	Temperature at anchoring base [°C]	Minimum curing time t_{cure} [min.] [hrs.]
		-5 - 0	24
0 - +5	13	> 0 - +5	3
> +5 - +10	9	> +5 - +10	90
> +10 - +20	5	> +10 - +20	60
> +20 - +30	4	> +20 - +30	45
> +30 - +40	2	> +30 - +40	35

The above times apply from the moment of contact between resin and hardener in the static mixer.

For installation, the cartridge temperature must be at least +5 °C. For longer installation times, i.e. when interruptions occur in work, the mixer should be replaced.

Curing times

FIS VS Plus Low Speed Cartridge temperature (mortar) [°C]	Maximum gelling time t_{work} [min.]	Temperature at anchoring base [°C]	Minimum curing time t_{cure} [min.] [hrs.]
		0 - +5	6
+5 - +10	20	> +5 - +10	3
> +10 - +20	10	> +10 - +20	2
> +20 - +30	6	> +20 - +30	60
> +30 - +40	4	> +30 - +40	30

The above times apply from the moment of contact between resin and hardener in the static mixer.

For installation, the cartridge temperature must be at least +5 °C. For longer installation times, i.e. when interruptions occur in work, the mixer should be replaced.

Curing times

FIS VW Plus High Speed Cartridge temperature (mortar) [°C]	Maximum gelling time t_{work} [min.]	Temperature at anchoring base [°C]	Minimum curing time t_{cure} [min.] [hrs.]
		-10 - -5	12
-5 - 0	5	> -5 - 0	3
> 0 - +5	5	> 0 - +5	3
> +5 - +10	3	> +5 - +10	50
> +10 - +20	1	> +10 - +20	30

The above times apply from the moment of contact between resin and hardener in the static mixer.

For installation, the cartridge temperature must be at least +5 °C. For longer installation times, i.e. when interruptions occur in work, the mixer should be replaced.

Loads

Injection system FIS V Plus with threaded rod FIS A resp. RG M

Permissible loads of a single anchor^{1) 2)} in normal concrete of strength class C20/25.
For the design the complete current assessment ETA-20/0603 has to be considered.

Type	Material / surface ³⁾	Effective anchorage depth h_{ef} [mm]	Minimum member thickness h_{min} [mm]	Maximum installation torque $T_{inst, max}$ [Nm]	Cracked concrete				Non-cracked concrete			
					Permissible tension (N_{perm}), shear loads (V_{perm}), minimum spacing (s_{min}) and edge distances (c_{min}) with reduced loads				Permissible tension (N_{perm}), shear loads (V_{perm}), minimum spacing (s_{min}) and edge distances (c_{min}) with reduced loads			
					$N_{perm}^{4)}$ [kN]	$V_{perm}^{4)}$ [kN]	$s_{min}^{4)}$ [mm]	$c_{min}^{4)}$ [mm]	$N_{perm}^{4)}$ [kN]	$V_{perm}^{4)}$ [kN]	$s_{min}^{4)}$ [mm]	$c_{min}^{4)}$ [mm]
FIS A M 8	5.8	60	100	10	3.9	6.3	40	40	9.0	6.3	40	40
	5.8	80	110	10	5.3	6.3	40	40	9.0	6.3	40	40
	5.8	160	190	10	9.0	6.3	40	40	9.0	6.3	40	40
	R-70	60	100	10	3.9	6.0	40	40	9.9	6.0	40	40
	R-70	80	110	10	5.3	6.0	40	40	9.9	6.0	40	40
	R-70	160	190	10	9.9	6.0	40	40	9.9	6.0	40	40
FIS A M 10	5.8	60	100	20	5.4	9.7	45	45	10.9	9.7	45	45
	5.8	90	120	20	8.1	9.7	45	45	13.8	9.7	45	45
	5.8	200	230	20	13.8	9.7	45	45	13.8	9.7	45	45
	R-70	60	100	20	5.4	9.2	45	45	10.9	9.2	45	45
	R-70	90	120	20	8.1	9.2	45	45	15.7	9.2	45	45
	R-70	200	230	20	15.7	9.2	45	45	15.7	9.2	45	45
FIS A M 12	5.8	70	100	40	8.2	14.3	55	45	13.7	14.3	55	45
	5.8	110	140	40	12.8	14.3	55	45	20.5	14.3	55	45
	5.8	240	270	40	20.5	14.3	55	45	20.5	14.3	55	45
	R-70	70	100	40	8.2	13.7	55	45	13.7	13.7	55	45
	R-70	110	140	40	12.8	13.7	55	45	22.5	13.7	55	45
	R-70	240	270	40	22.5	13.7	55	45	22.5	13.7	55	45
FIS A M 16	5.8	80	120	60	11.5	23.0	65	50	16.8	26.9	65	50
	5.8	125	170	60	18.0	26.9	65	50	32.7	26.9	65	50
	5.8	320	360	60	37.6	26.9	65	50	37.6	26.9	65	50
	R-70	80	120	60	11.5	23.0	65	50	16.8	25.2	65	50
	R-70	125	170	60	18.0	25.2	65	50	32.7	25.2	65	50
	R-70	320	360	60	42.0	25.2	65	50	42.0	25.2	65	50
FIS A M 20	5.8	90	140	120	14.0	28.0	85	55	20.0	40.0	85	55
	5.8	170	220	120	28.0	42.3	85	55	51.9	42.3	85	55
	5.8	400	450	120	58.6	42.3	85	55	58.6	42.3	85	55
	R-70	90	140	120	14.0	28.0	85	55	20.0	39.4	85	55
	R-70	170	220	120	28.0	39.4	85	55	51.9	39.4	85	55
	R-70	400	450	120	65.7	39.4	85	55	65.7	39.4	85	55
FIS A M 24	5.8	96	160	150	15.4	30.8	105	60	22.0	44.1	105	60
	5.8	210	270	150	37.7	60.6	105	60	71.3	60.6	105	60
	5.8	480	540	150	84.3	60.6	105	60	84.3	60.6	105	60
	R-70	96	160	150	15.4	30.8	105	60	22.0	44.1	105	60
	R-70	210	270	150	37.7	56.8	105	60	71.3	56.8	105	60
	R-70	480	540	150	86.2	56.8	105	60	94.3	56.8	105	60
FIS A M 30	5.8	120	190	300	21.6	43.1	140	80	30.8	61.6	140	80
	5.8	280	350	300	56.5	96.0	140	80	109.8	96.0	140	80
	5.8	600	670	300	121.2	96.0	140	80	133.8	96.0	140	80
	R-70	120	190	300	21.6	43.1	140	80	30.8	61.6	140	80
	R-70	280	350	300	56.5	90.2	140	80	109.8	90.2	140	80
	R-70	600	670	300	121.2	90.2	140	80	150.1	90.2	140	80

¹⁾ Design according to EN 1992-4:2018 (for static resp. quasi-static loads). The partial safety factors for material resistance as regulated in the ETA as well as a partial safety factor for load actions of $\gamma_L = 1.4$ are considered. As a single anchor counts e.g. an anchor with a spacing $s \geq 3 \times h_{ef}$ and an edge distance $c \geq 1.5 \times h_{ef}$. Accurate data see ETA.

²⁾ The specified loads are valid for anchorages in dry and damp concrete. For temperatures in the anchoring substrate up to 50 °C (resp. short term up to 80 °C). Drill hole cleaning as per specification in the ETA. The factor ψ_{sus} was taken into account with 1.0.

³⁾ Further steel grades, versions and technical data see ETA, e.g. for dry internal conditions, galvanised steel (gvz); for damp interior stainless steel (R) and exterior conditions, e.g. material 1.4362 or 1.4401.

⁴⁾ In the case of combinations of tensile and shear loads, bending moments with reduced or minimum spacing and edge distances (anchor groups), the design must be carried out in accordance with the provisions of the complete ETA and the provisions of the EN 1992-4:2018. We recommend using our anchor design software C-FIX.

Loads

Injection system FIS V with threaded rod FIS A

Permissible loads¹⁾²⁾ for a single anchor in masonry for pre-positioned or push-through installation.
For the design the complete current assessment ETA-20/0729 has to be considered.

Type	Compressive brick strength f_b [N/mm ²]	Brick raw density ρ [kg/dm ³]	Minimum brick dimensions ³⁾ (L x B x H) [mm]	Minimum effective anchor-age depth h_{ef} [mm]	Minimum member thickness h_{min} [mm]	Maximum installation torque $T_{inst,max}$ [Nm]	Permissible tensile load ⁴⁾ N_{perm} [kN]	Permissible tensile load ⁴⁾ V_{perm} [kN]	Minimum-spacing ⁵⁾ $s_{min} \parallel / s_{min} \perp$ [mm]	Characteristic resp. minimum edge distance ⁵⁾ $c_{cr} = c_{min}$ [mm]
Solid brick Mz, NF, acc. to EN 771-1										
M6	≥ 12	≥ 1.8	240 x 115 x 71	50	115	4	1.14	0.71	240 / 75	100
M8	≥ 12	≥ 1.8	240 x 115 x 71	50	115	10	1.14	0.71	240 / 75	100
M10	≥ 12	≥ 1.8	240 x 115 x 71	50	115	10	1.00	1.14	240 / 75	100
M12	≥ 12	≥ 1.8	240 x 115 x 71	50	115	10	0.86	1.14	240 / 75	100
Solid sand-lime brick KS, acc. to EN 771-2										
M6	≥ 10	≥ 2.0	250 x 240 x 240	50	240	4	1.43	0.71	80 / 80	60
M8	≥ 10	≥ 2.0	250 x 240 x 240	50	240	10	2.00	1.29	80 / 80	60
M10	≥ 10	≥ 2.0	250 x 240 x 240	50	240	10	2.00	1.29	80 / 80	60
M12	≥ 10	≥ 2.0	250 x 240 x 240	50	240	10	2.00	1.29	80 / 80	60
M16	≥ 10	≥ 2.0	250 x 240 x 240	50	240	10	1.57	1.29	80 / 80	60
Vertically perforated brick Hlz, acc. to EN 771-1										
FIS H 12 x 50 K M6 / M8	≥ 4	≥ 1.0	500 x 175 x 237 or 370 x 240 x 237	50	175	2	0.11	0.14	100 / 100	100
FIS H 16 x 85 K M8 / M10	≥ 4	≥ 1.0	500 x 175 x 237 or 370 x 240 x 237	85	175	2	0.26	0.14	100 / 100	100
FIS H 20 x 130 K M12 / M16	≥ 4	≥ 1.0	500 x 175 x 237 or 370 x 240 x 237	130	175	2	0.34	0.17	100 / 100	100
Perforated sand-lime brick KSL, acc. to EN 771-2										
FIS H 12 x 50 K M6 / M8	≥ 12	≥ 1.4	240 x 175 x 113	50	175	2	0.71	0.71	100 / 115	60
FIS H 16 x 85 K M8 / M10	≥ 12	≥ 1.4	240 x 175 x 113	85	175	2	0.86	1.29	100 / 115	80
FIS H 20 x 85 K M12	≥ 12	≥ 1.4	240 x 175 x 113	85	175	2	1.00	1.29	100 / 115	80
Lightweight concrete hollow block Hbl, acc. to EN 771-3										
FIS H 12 x 50 K M6 / M8	≥ 2	≥ 1.0	362 x 240 x 240	50	240	2	0.34	0.26	100 / 240	60
FIS H 16 x 85 K M8 / M10	≥ 2	≥ 1.0	362 x 240 x 240	85	240	2	0.43	0.26	100 / 240	60
FIS H 20 x 200 K M12 / M16	≥ 2	≥ 1.0	362 x 240 x 240	180	240	2	0.71	0.26	100 / 240	60
Aerated concrete acc. to EN 771-4										
M8 ⁶⁾	≥ 2	≥ 0.35	-	100	130	1	0.54	0.43	250	100
M10 ⁶⁾	≥ 2	≥ 0.35	-	100	130	2	0.54	0.43	250	100
M12 ⁶⁾	≥ 2	≥ 0.35	-	100	130	2	0.71	0.54	250	100
M16 ⁶⁾	≥ 2	≥ 0.35	-	100	130	2	0.71	0.43	250	100
M8, M10, M12 ⁷⁾	≥ 2	≥ 0.35	-	75	105	2	0.71	0.89	240	120
M8, M10, M12 ⁷⁾	≥ 2	≥ 0.35	-	95	125	2	0.89	0.89	300 / 250	150

¹⁾ The required partial safety factors for material resistance as well as a partial safety factor for load actions of $\gamma_L = 1.4$ are considered. Load values are valid for zinc-plated steel, stainless steel R and highly corrosion-resistant steel HCR.

²⁾ The given loads are valid for installation and use of fixations in dry masonry - use category d/d - for temperatures in the substrate up to 50 °C (resp. short term up to 80 °C) and drill hole cleaning according to assessment. The given brick types in combination with the permissible loads are an extract of the assessment.

³⁾ Hole patterns see assessment.

⁴⁾ In the case of combinations of tensile and shear loads, bending moments and reduced edge and axial spacings (anchor groups), the design must be carried out in accordance with the provisions of the complete assessment.

⁵⁾ Minimum feasible spacing resp. edge distance. Details as well as to the distances to joints see assessment.

⁶⁾ Cylindrical drill hole.

⁷⁾ Conical drill hole.

Loads

Injection system FIS V Plus with internal threaded anchor RG M I

Permissible loads of a single anchor¹⁾²⁾ in normal concrete of strength class C20/25.
For the design the complete current assessment ETA-20/0603 has to be considered.

Type	Screw Material ³⁾	Effective anchor- age depth h_{ef} [mm]	Minimum member thickness h_{min} [mm]	Maximum installa- tion torque $T_{inst, max}$ [Nm]	Non-cracked concrete			
					Permissible tension (N_{perm}), shear loads (V_{perm}), minimum spacing (s_{min}) and edge distances (c_{min}) with reduced loads			
					$N_{perm}^{4)}$ [kN]	$V_{perm}^{4)}$ [kN]	$s_{min}^{4)}$ [mm]	$c_{min}^{4)}$ [mm]
RG M 8 I	5.8	90	120	10	9.0	5.3	55	55
	8.8	90	120	10	13.8	8.3	55	55
	R-70	90	120	10	9.9	5.9	55	55
RG M 10 I	5.8	90	130	20	13.8	8.3	65	65
	8.8	90	130	20	20.0	13.3	65	65
	R-70	90	130	20	15.7	9.3	65	65
RG M 12 I	5.8	125	170	40	20.5	12.1	75	75
	8.8	125	170	40	32.0	19.3	75	75
	R-70	125	170	40	22.5	13.5	75	75
RG M 16 I	5.8	160	210	80	37.6	22.4	95	95
	8.8	160	210	80	47.4	30.9	95	95
	R-70	160	210	80	42.0	25.1	95	95
RG M 20 I	5.8	200	260	120	58.6	35.4	125	125
	8.8	200	260	120	66.3	51.4	125	125
	R-70	200	260	120	65.7	39.4	125	125

¹⁾ Design according to EN 1992-4:2018 (for static resp. quasi-static loads). The partial safety factors for material resistance as regulated in the ETA as well as a partial safety factor for load actions of $\gamma_L = 1.4$ are considered. As a single anchor counts e.g. an anchor with a spacing $s \geq 3 \times h_{ef}$ and an edge distance $c \geq 1.5 \times h_{ef}$. Accurate data see ETA.

²⁾ The specified loads are valid for anchorages in dry and damp concrete. For temperatures in the anchoring substrate up to 50 °C (resp. short term up to 80 °C). Drill hole cleaning as per specification in the ETA. The factor Ψ_{sus} was taken into account with 1.0.

³⁾ Further steel grades, versions and technical data see ETA, e.g. for dry internal conditions, galvanised steel (gvz); for damp interior stainless steel (R) and exterior conditions, e.g. material 1.4362 or 1.4401.

⁴⁾ In the case of combinations of tensile and shear loads, bending moments with reduced or minimum spacing and edge distances (anchor groups), the design must be carried out in accordance with the provisions of the complete ETA and the provisions of the EN 1992-4:2018. We recommend using our anchor design software C-FIX.